

CONNECTED ARROW BOARD 15 LIGHTS

Clearly indicate lane closures on the road and online. Ver-Mac's connected arrow board sends audible and visual alerts to Waze, letting motorists know an upcoming lane is closed.

Ver-Mac products support the Connected Work Zone (CWZ)* data-sharing specification, so you can opt to send lane closure information to government agencies and other relevant parties.

With its autonomy, connectivity and durable design, the ST-4815 is an innovative, cost-effective option to secure your work zone.

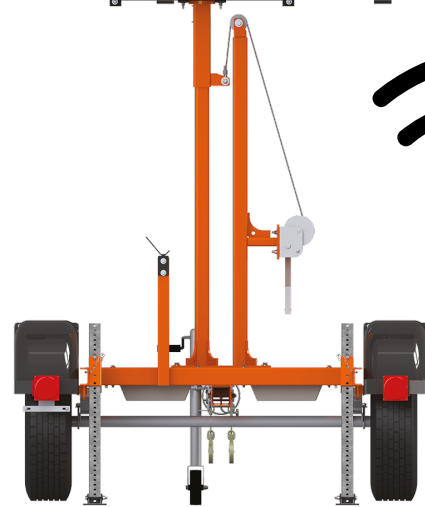

CONNECTED ARROW BOARD

INDICATES

Lane closure start location
Mode displayed on arrow board

COMMUNICATES INFORMATION

Real-time audible and visual alert on Waze
Compatible with some infotainment and navigation systems
Supports CWZ* feeds

ACTIVITY LOG

GPS location, ON/OFF, mode, status

MANAGE VIA JAMLOGIC

Map and list view in JamLogic
Remote asset management including location and battery monitoring even if it is turned OFF
Monitor arrow, solar & battery status in real time

APPLICATIONS

- Highway construction
- City and county
- Department of Transportation (DOT)
- Utility projects
- Connected Work Zones



FEATURES & BENEFITS

DURABLE, EASY TO USE

STEALTH TECHNOLOGY

Maintenance-free batteries
Anti-theft hidden battery compartment

V-SWITCH CONTROLLER

Quickly select arrow patterns/mode with rotary switch

4 ADJUSTABLE TELESPAR LEGS

Stabilization and easy transportation

TONGUE WHEEL JACK

Easy and safe trailer setup

REMOVABLE TONGUE

Saves space for storage or locations with tight space

MANUAL LIFT MECHANISM

Robust winch for quick deployment

RUGGED INDEXED ROD MAST BRAKE

240° rotation (15° increments)

2-IN. (51 MM) COUPLER OR 3-IN. (76 MM) PINTLE EYE

For easy towing

DIAMOND PLATE PLATFORM

For safe and easy maintenance

SINGLE-MAST DESIGN

SAFER TO USE

EFFICIENT TRANSPORTATION & STORAGE

LESS WIND DRAG, LOWER FUEL COSTS

QUICK AND EASY SETUP

ENERGY-EFFICIENT DESIGN

SOLAR PANELS

Provide maximum recharging year-round. Designed to run 12 months in most regions without manual charging

SOLAR REGULATOR

With high-efficiency MPPT to maximize solar energy harvesting

OPTIBRIGHT TECHNOLOGY

Exclusive energy-efficient lens mold
Easier lamp replacement
Autonomous and hassle-free
Photocell with automatic adjustment

SPECIFICATIONS

DISPLAY

- Arrow board panel: 48 x 96 in. (1219 x 2438 mm)
- 15 LED lamps with OptiBright Technology
- 2 back LED lights
- 28 LEDs per lamp

DIMENSIONS & WEIGHTS

- Overall length: 134 in. (3415 mm)
- Overall width: 96 in. (2438 mm)
- Operating height: 135 1/2 in. (3442 mm)
- Traveling width: 70 in. (1788 mm)
- Traveling height: 93 in. (2362 mm)
- Weight (approx.): 920 lb. (420 kg)

OPTIONS

- Compass to report heading in real time
 - See deployment status (operational or transport mode)
 - CWZ data-sharing feeds
- Other options are available to meet your needs.*

WARRANTY

- 1 year on complete trailer
- 2 years on electronic components manufactured by Ver-Mac

